



Control and Indicating Equipment

Requirements and Test Methods

Publishing house: VdS Schadenverhütung GmbH

Amsterdamer Str. 172-174

50735 Köln, Germany

Phone: +49 221 77 66 0; Fax: +49 221 77 66 341

Copyright by VdS Schadenverhütung GmbH. All rights reserved.

VdS Guidelines for Fire Detection and Fire Alarm Systems

Control and Indicating Equipment

Requirements and Test Methods

Contents

1	General	4
1.1	Scope.....	4
1.2	Validity	4
2	Normative references	4
3	Definitions	4
4	Requirements and test methods	5
4.1	General	5
4.2	Requirements and test methods of DIN EN 54-2	5
4.3	Additional functions.....	7

1 General

Tests in accordance with these Guidelines shall be carried out by a testing body accredited in accordance with DIN EN ISO/IEC 17025.

1.1 Scope

These Guidelines specify requirements, test methods and performance characteristics for control and indicating equipment for the use in automatic fire detection and fire alarm systems installed in buildings, applicable in accordance with the relevant Guidelines for planning and installation VdS 2095.

These Guidelines are relevant in addition to European standard EN 54-2 harmonised in accordance with the Construction Products Directive of the European Union.

They are mandatory only if their application is agreed on an individual basis. Otherwise they are not binding; an agreement on the application of these Guidelines is purely optional.

1.2 Validity

These Guidelines are valid as of their date of publishing.

2 Normative references

These Guidelines incorporate, by dated or undated references, provisions from other publications (e.g. European standards EN), as specified below.

For dated references to other publications amendments to or revisions of any of these publications apply to these Guidelines only when incorporated in them by amendment or revision. For undated references the latest edition of the publication referred to applies.

DIN EN 54-1 Fire detection and fire alarm systems – Part 1 : Introduction

DIN EN 54-2 Fire detection and fire alarm systems – Part 2 : Control and indicating equipment

DIN 14675 Fire detection and fire alarm systems – Configuration and operation

DIN 14661 Firefighting equipment – Fire brigade control panel for fire detection and fire alarm systems

DIN 14662 Firefighting equipment – Fire brigade indicator panel for fire detection and fire alarm systems

VdS 2496 Triggering of fire extinguishing systems

3 Definitions

For an application of these Guidelines the definitions specified in the a.m. regulations apply.

4 Requirements and test methods

For compliance with these Guidelines, control and indicating equipment shall fulfil the following requirements:

- the relevant requirements of product standard DIN EN 54-2; and
- the requirements of these Guidelines.

4.1 General

The general test and connection conditions of DIN EN 54-2 apply.

4.2 Requirements and test methods of DIN EN 54-2

4.2.1 Requirements

On principle, the requirements of DIN EN 54-2 apply.

In addition, the following options with requirements of DIN EN 54-2 shall be implemented as specified below:

Option with requirements of DIN EN 54-2	DIN EN 54-2, Cl.	Option...	Note
Controls:			
Delays to outputs			
Output C	7.11.1	may be provided	2)
Output E	7.11.1	may be provided	2)
Output G	7.11.1	not permitted	
Provision to switch on/off delays	7.11.2	shall be provided	
Dependencies on more than one alarm signal			
Type A dependency	7.12.1	may be provided	1)
Type B dependency	7.12.2		
<ul style="list-style-type: none"> • Confirmation alarm signal from the same fire detector 		may be provided	1), 2)
<ul style="list-style-type: none"> • Confirmation alarm signal from another fire detector in the same zone 		shall be provided	2), 3)
<ul style="list-style-type: none"> • Confirmation alarm signal from another fire detector in another zone 		may be provided	2), 3)
Type C dependency	7.12.3	not permitted	
Disablement of addressable points	9.5	may be provided	
Test condition	10	shall be provided	

Option with requirements of DIN EN 54-2	DIN EN 54-2, Cl.	Option...	Note
Inputs/Outputs:			
Output to fire alarm devices	7.8	shall be provided	4)
Control of fire alarm routing equipment			4)
Output to fire alarm routing equipment	7.9.1	shall be provided	4)
Alarm confirmation input from fire alarm routing equipment	7.9.2	shall be provided	
Outputs to fire protection equipment			4)
Output type A	7.10.1	may be provided	
Output type B	7.10.2	may be provided	
Output type C	7.10.3	shall be provided	
Fault monitoring of fire protection equipment	7.10.4	shall be provided	
Output to fault warning routing equipment	8.9	shall be provided	
Standardised input/output interface	11	may be provided	
Indications:			
Alarm counter	7.13	shall be provided	
Fault signals from points	8.3	may be provided	
Total loss of the power supply	8.4	may be provided	
Notes:			
1) strictly not permitted for the triggering of fire extinguishing systems in accordance with VdS 2496			
2) not permitted in combination with a manual call point			
3) A confirmation alarm signal from another fire detector in another zone shall be required, if a confirmation signal from another fire detector in the same zone is technically impossible.			
4) The interfaces for the triggering of fire alarm routing equipment and of control and alarm devices not incorporated in the fire detection system shall comply with DIN 14675 Annex B, Table B.1. These requirements do not apply to interfaces for the triggering of fixed fire extinguishing systems.			

4.2.2 Test methods

Testing for compliance with the requirements specified in 4.2.1 of DIN EN 54-2, Cl. 4 to 14 by visual inspections and functional tests and check of the documentation.

DIN EN 54-2, Cl. 15, Test for environmental stability as specified. Exception: In the test according to DIN EN 54-2, Cl. 15.8.1 d) "Radiated electromagnetic fields" the field strength is increased to 30 V/m in the range (890-960) MHz at increments of 3 MHz.

Testing of inputs/outputs acc. DIN EN 54-2, Cl. 7.8, 7.9, 7.10 and testing of interfaces for compliance with the requirements of DIN 14675 Annex B, Table B.1.

4.3 Additional functions

4.3.1 Triggering of fire extinguishing systems

On principle, the control and indicating equipment shall have provision for a standardised interface for extinguishing systems in accordance with VdS 2496 for the triggering of fire extinguishing systems.

Note 1: The standardised interface for extinguishing systems may be omitted, provided that the fire detection and fire extinguishing systems are tested as one system and their compatibility is thus verified.

Note 2: The standardised interface for extinguishing systems may comprise an output in accordance with 7.10.3 and an input in accordance with 7.10.4 of DIN EN 54-2.

4.3.1.1 Requirements

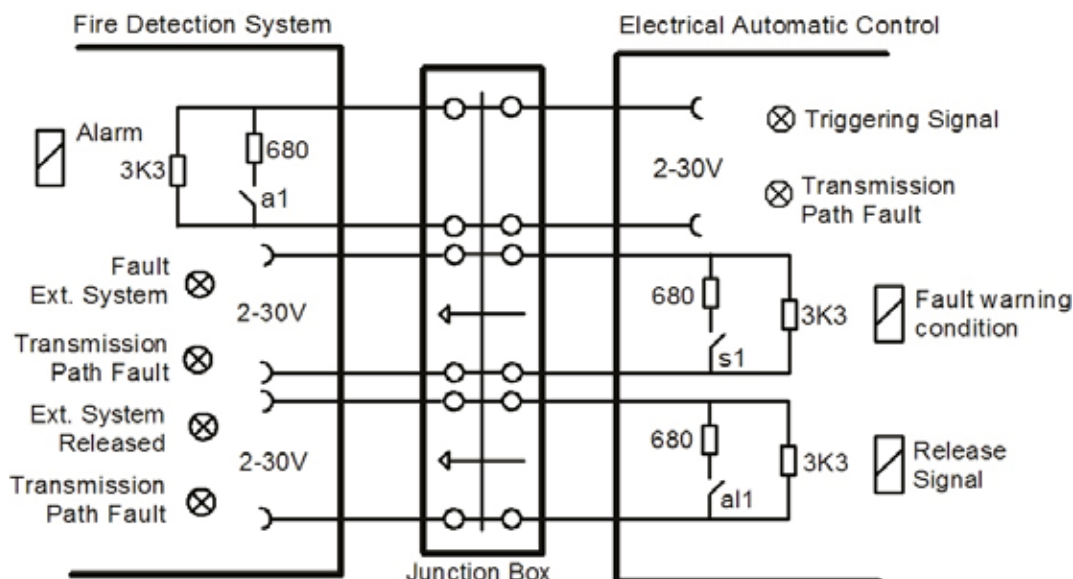

Designation of terminals in the control and indicating equipment

The terminals of the interface for the triggering of an extinguishing system in or at the control and indicating equipment shall be marked "Extinguishing System".

Indications

The indications for "Extinguishing System released" and "Fault Extinguishing System" shall be by means of separate light emitting indicators and/or an alphanumeric display.

At least one common indication each for "Extinguishing System Released" and "Fault Extinguishing System" is required; they shall not be suppressed during the fire alarm condition.

It shall be possible to interrogate suppressed indications for "Extinguishing System Released" and "Fault Extinguishing System" at access level 1.

The indications for “Transmission Path Fault” shall be by means of separate light emitting indicators and/or an alphanumeric display. These indications may be suppressed during the fire alarm condition.

The indications “Transmission Path Fault” and “Fault Extinguishing System” shall be yellow. The indication “Extinguishing System Released” shall be red.

For alphanumeric displays no colour differentiation of the indications is required.

4.3.1.2 Test method

Testing for compliance with the requirements of 4.3.1.1 with regard to connection, function and indications by functional test and visual inspection.

4.3.2 Fire brigade control panel

4.3.2.1 Requirements

The control and indicating equipment shall have provision for an interface in accordance with DIN 14675 Annex D for the connection of a fire brigade control panel in accordance with DIN 14661.

4.3.2.2 Test method

Testing of the interface for compliance with the requirements of DIN 14675 Annex D by measurement of the parameters and functional test, and testing for compliance with the required indicating and control functions specified in DIN 14661 in interaction with the control and indicating equipment by functional test and visual inspection.

4.3.3 Fire brigade indicator panel

4.3.3.1 Requirements

If a fire brigade indicator panel is to be connected to the control and indicating equipment, the control and indicating equipment shall have provision for an interface for the connection of a fire brigade indicator panel in accordance with DIN 14662.

4.3.3.2 Test method

Testing for compliance with the indicating and control functions specified in DIN 14662 in interaction with the control and indicating equipment by functional test and visual inspection.

